

# SHAMROCK



by

**Austwide**  
sales and rentals pty ltd

## AGD420:- SINGLE GLASS DOOR SERIES



*Pictured with additional row of shelves*

### AGD420

#### FEATURES:

- Operating Temperature 0° to +5° C @ ambient temperature of 40° C
- Only requires one standard power point (GPO):- 240V 50Hz 10 amp.
- Digital Temperature Display.
- Individual adjustable shelves per door maximizing display configurations.
- Individual light switch to interior and signage.
- Double glazed thermal insulated doors to reduce power consumption.
- Aluminium Framed doors with locks.
- Positive seal torsion bar self closing doors for low maintenance.
- Commercial castors, for ease of cabinet movement.
- Cyclic defrost with timed backup insures frost free refrigeration.
- Auto hot gas condensate removal requires no pumping.

#### MAIN DATA

Specifications are subject to change without notice. E&OE.

Model	Doors	Volume (Net lts)	Shelves	Dimensions (mm) Width x Depth x height	Voltage	Power	Cord Length	Shipping Weight
<b>AGD420</b>	1	412	4	680 x 720 x 2045	240v/50hz	3 amp	2.4	138kg

Head Office: Unit 1/35 Rimfire Drive ,Hallam, Vic 3803. Phone: 1800 813 987 Fax: 03 8786 3572  
Email: sales@austwiderentals.com websites: www.austwidesales.com.au or austwiderentals.com

# SHAMROCK



by

**Austwide**  
sales and rentals pty ltd

## AGD420:- SINGLE GLASS DOOR SERIES

### Specification

- **Shelves:** 4 height adjustable, PVC coated, shelves per door. 4 stainless steel shelf clips per shelf fit to stainless steel shelf posts.
- **Lighting:** Florescent 36watt 1200mm tubes recessed into the inner walls provide high visibility lighting, with low replacement cost.
- **Refrigeration System:** Fully balanced self contained condensing unit with forced draught evaporator and condenser.
- **Compressor.** SECOP, formerly Danfoss compressors.
- **Refrigerant:** R134A.
- **Defrost:** Cyclic defrost, with no-cost, hot gas condensate disposal. Supplemented with timed defrosts via electronic controller.
- **Electronic Controller:** Italian designed and Manufactured, Dixell temperature controller.
- **Evaporator:** Epoxy coated to minimize the potential of corrosion and thus future gas leaks.
- **Operation conditions:** 0° to 5° C. at up to 40° C ambient.
- **Electrical:** Units come ready for connection to 240volt 50hz 10amp GPO. It is recommended that a ded-

icated GPO be used.

- **Construction:** Corrosion resistant Pre-painted steel interior and exterior
- **Insulation:** 50mm high density polyurethane foamed in place, Blowing agent, Cyclopentane for CFC free Ozone protection and superior insulating properties.
- **Door:** Double glazed thermal insulated toughened glass. Constructed with aluminium frame and fitted with locks.
- **Hinging:** Self closing torsion spring.
- **Gasket:** PVC welded one piece magnetic gasket. Removable without the need for tools.
- **Castors:** 4 (2 x locking) x 75mm swivel commercial castors.
- **Model Features:** Digital Temperature readout.
- **Warranty<sup>1</sup>:** Austwide's Manufacturer's warranty 12 month parts and labour. See terms and conditions of sale for full description.
- **Optional Extras:**
  - Additional Shelves.
  - Livery to sides and illuminated sign.

### Outstanding Benefits

- **Condensing unit:** Bottom mounted

placing the unit in the coolest position, close to the floor, which puts less strain on the refrigeration system providing longer life and greater efficiency.

- **Optimal product placement:** The G420 lifts the product off the floor, placing it in the optimal position for your customers to easily reach in and retrieve without the need to stoop down excessively.
- **AGD Series also available in a two Door:** AGD920 pictured. There is also a matching Freezer Series AFD Series.



AGD920 shown with additional row of shelves.  
Dims (mm) : 1370w x 720d x 2090h

ELEVATIONS. (not to scale)

<sup>1</sup>.terms and conditions apply. Visit web site for full details. [www.austwidesales.com.au](http://www.austwidesales.com.au)  
Specifications are subject to change without notice. E&OE.

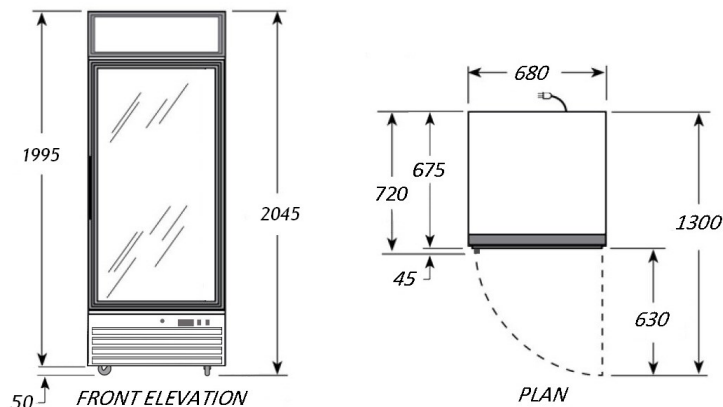

Head Office: Unit 1/35 Rimfire Drive ,Hallam, Vic 3803. Phone: 1800 813 987 Fax: 03 8786 3572  
Email: [sales@austwiderentals.com](mailto:sales@austwiderentals.com) websites: [www.austwidesales.com.au](http://www.austwidesales.com.au) or [austwiderentals.com](http://austwiderentals.com)