

SHAMROCK



by



AGD & AFD SERIES:- GLASS DOOR REFRIGERATORS & FREEZERS



AGD420 & AFD420



AFD920 & AFD930

FEATURES:

- Only requires one standard power point (GPO):- 240V 50Hz 10 amp.
- Digital Temperature Display and separate light switch behind hinged cover.
- Individual adjustable shelves per door maximizing display configurations.
- Individual light switch to interior and signage.
- Triple glazed thermal insulated heated glass doors to freezers.
- Aluminium Framed doors with locks.
- Positive seal torsion bar self closing doors for low maintenance.
- Commercial castors, for ease of cabinet movement.
- Fan forced Evaporators for positive air flow and cooling.
- Auto hot gas condensate removal requires no pumping.
- Painted High Gloss Black Exterior.
- Operating Temperatures:
AGD420 / AGD920: 0° to 10°C @ 38° ambient.
AFD420 / AFD930: -18° to -22°C @ 32° ambient.

AGD920B - Refrigerator
AFD930B - Freezer

MAIN DATA

Specifications are subject to change without notice. E&OE.

Model	Doors	Volume (Net L)	Shelves	Dimensions (mm) Width x Depth x height	Voltage	Power Outlet	Cord Length	Shipping Weight
AGD420B / AFD420B	1	412	4	680 x 720 x 2045	240v/50hz	10 amp	2.4	138kg
AFD920B / AGD930B	2	920	8	1370 x 720 x 2045	240v/50hz	10 amp	2.4	227kg

Head Office: Unit 1/35 Rimfire Drive, Hallam, Vic 3803. Phone: 1800 813 987 Fax: 03 8786 3572

Email: sales@austwiderentals.com websites: www.austwidesales.com.au or austwiderentals.com

SHAMROCK



by

Austwide
sales and rentals pty ltd

PRODUCT SPECIFICATIONS

Model	AGD420	AFD420	AGD920	AFD930
External Dimensions (mm)	680w x 720d x 2045h		1370w x 720d x 2045h	
Internal Dimensions (mm)	560w x 580d x 1270h		1250w x 580d x 1270h	
Capacity (L)	412		920	
Operating Temperature	0° ~ 10°C @ 38°C	-18° ~ -24°C @ 32°C	0° ~ 10°C @ 38°C	-18° ~ -24°C @ 32°C
Doors	1		2	
No. of Shelves	5		10	
Refrigerant	R134A	R404A	R134A	R404A
Defrost System	Cyclic	Electric	Cyclic	Electric
Compressor Make	EMBRACO			
Cooling Type	Ventilated - Fan Forced Evaporator			
Insulation Type	Polyurethane			
Temperature Control Type	Dixell			
Amps (Voltage 240V/50hz)	2	4.5	3	5
Energy Consumption (Kwh/24h)	3.8	13	7.5	25
Net Weight (kg)	138	138	227	227

ELEVATIONS. (not to scale)

1. terms and conditions apply. Visit web site for full details. www.austwidesales.com.au
Specifications are subject to change without notice. E&OE.

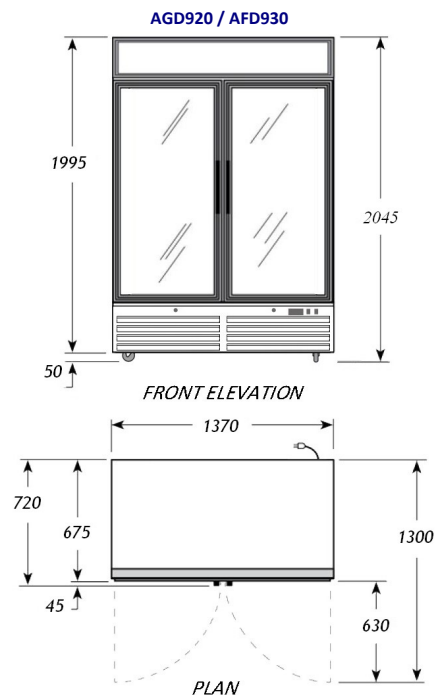
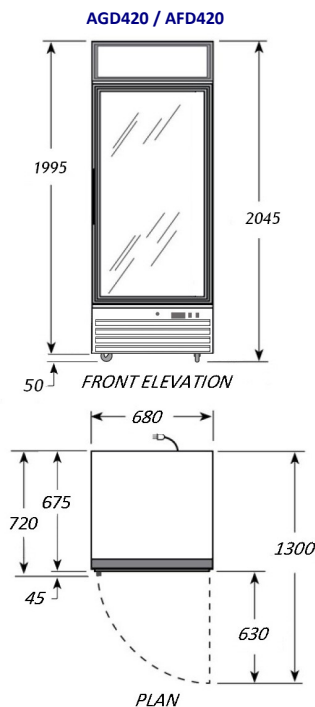

Head Office: Unit 1/35 Rimfire Drive, Hallam, Vic 3803. Phone: 1800 813 987 Fax: 03 8786 3572
Email: sales@austwiderentals.com websites: www.austwidesales.com.au or austwiderentals.com